

# RECOVERY OF CHROMIUM FROM LEATHER SHAVINGS BY WET AIR OXIDATION METHOD

Hiroshi OKAMURA

## ABSTRACT

Leather shavings discharged as wastes from tanneries may cause the environmental pollution, owing to the high contents of chromium, regardless of whether these are incinerated or dumped into the ground. In the present study, attempts were made to decompose organic compounds in the shavings by the wet air oxidation method and to separate chromium from the oxidized liquor thus formed. There are two ways for the oxidation of chromium, one converts chromium to hexavalent ion, and the other to trivalent ion. As to the former method, the oxidation was performed by the addition of NaOH, 80% by weight based on the dry weight of the shavings, and by this treatment almost all chromium in the shavings were converted to the hexavalent state, and this hexavalent chromium would be able to separate from the oxidized liquor by means of an ion exchange resin or the like.

On the other hand, as the formation of trivalent chromium, this oxidation was performed with 10 to 20 percent of  $H_2SO_4$ , based on the dry weight of the shavings, the majority of the chromium contained in the shavings were sedimented as brown sand-like precipitates with a low water content, and such precipitates are readily separable by filtration. As this filtrate still contains a considerable amount of dissolved chromium, this can not be discharged outside, but the recyclic use of the filtrate enables the treatment of shavings without any leak of dissolved chromium from the system.

## INTRODUCTION

Tannery wastes, either liquid or solid, are difficult to purify satisfactorily by the usual coagulation-sedimentation combination method alone, since these are high in COD and in organic solids contents.

As reported previously (1), however, the wet air oxidation method, applied as a preliminary treatment to tannery wastes, was proved to remove over 80% of COD and to decompose fleshings and other solids, which require tedious work in handling, to the form of a clear aqueous solution.

Leather shavings, together with fleshings, make up the principal materials discharged from tanneries and a variety of methods have been devised for the utilization of these material effectively, and some of them are practically applied (2-5). However, it is not easy to collect and utilize all the leather shavings discharged from small

tanneries. Rather, there are so many cases to dispose these shavings simply as wastes. Even in these cases, there is no guarantee that shavings would not produce pollution by chromium contained in these, whether these are incinerated (6) or dumped into the ground without treatment. Therefore, it become necessary to develop the new methods to recover chromium from the shavings or at least to keep chromium in the tanneries and not to discharge them.

In this study, attempts were made to decompose organic components in shavings by wet air oxidation method and to separate chromium from the oxidized liquor. For the separation of chromium in aqueous liquor, there are two conceivable methods, one is the method to separate it as trivalent chromium ion and other as hexavalent ion, and on these methods the investigation were undertaken.

## EXPERIMENTALS

### 1. Samples(Leather shavings)

Salted ox hide(20 lbs), imported from the United States, was chrome-tanned and shaved, and the shavings thereby produced were dried in air. Moisture content: 17.0%, pH: 3.1, chromium content: 3.62% as  $\text{Cr}_2\text{O}_3$  and COD: 0.94g/g

### 2. Procedure for Wet Air Oxidation

The wet air oxidation was carried out with the laboratory autoclave, manufactured by Niigata-Zimpuro, internal volume of reaction chamber: 800 ml, maximum temperature:  $300^\circ\text{C}$ , maximum pressure: 300kg/sq.cm, the chamber is lined with titanium and the autoclave is shaken by a reciprocator.

As shown in Fig.1, the definite amounts of sample of known COD and water were put into the autoclave and sealed. The autoclave was introduced into the electric oven, and air was injected into the autoclave through the air bomb,

and the volume of air introduced was setted to 1.25 times as much oxygen required for the oxidation of sample calculated from COD. The volume of air injected was calculated from the reading of the pressure gauge and the internal air space of the autoclave. In this case, the volume of air, the volume of water (namely, the volume of internal air space), and the amount of sample were controlled so that the sum of the pressure predicted for the prescribed reaction temperature and the pressure of water vapor at this temperature equaled to the prescribed reaction pressure. The ratio of sample to water added was chosen, in principle, so that COD became 94 g/l. In the electric oven, the temperature of autoclave was raised to the prescribed reaction temperature about one hour after the heating. The temperature was controlled by means of the thermocouple. When the specified temperature was reached, the reciprocator was turned on to initiate the reaction. As to the reaction period one hour was chosen, in principle, and after the reaction, the

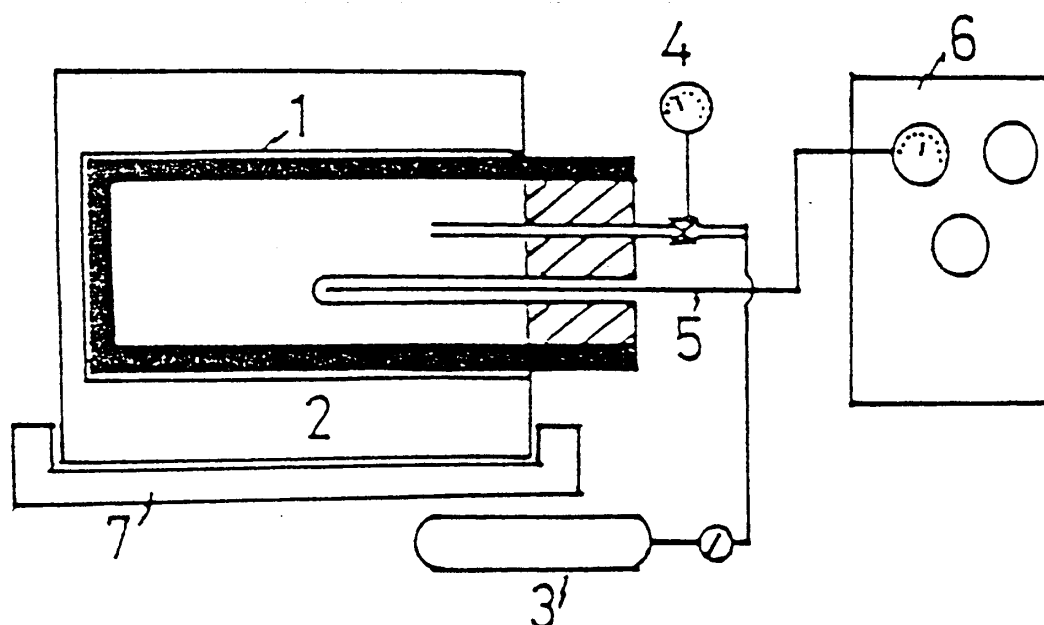

FIGURE 1. APPARATUS FOR WET AIR OXIDATION.  
1: autoclave, 2: electric oven, 3: air bomb, 4: pressure gauge,  
5: thermocouple, 6: control panel, 7: reciprocator.

## RECOVERY OF CHROMIUM FROM LEATHER SHAVINGS

reciprocator was then turned off and the reaction vessel was allowed to cool.

The temperature of reaction mixture was maintained constant within  $\pm 5^{\circ}\text{C}$  during the reaction by the aid of an automatic temperature controller. After the cooling, the reaction mixture was taken out and analyzed for the residual COD.

The reaction conditions used were as follows: shavings charged: 100 g/l; oxygen injected 125% (1.25 times of the COD of the shavings).

### 3. Analyses of the Oxidized Liquor

The oxidized liquor was centrifuged at 3,000 rpm and the supernatant was submitted to analysis. COD was determined by the potassium dichromate method. The total chromium content was determined by the titration method of the usual manner by evaporating the above supernatant to dryness, burning the residue to ashes and fusing it with sodium peroxide. The content of hexavalent chromium was determined by applying diphenylcarbazide colorimetry to the supernatant.

## RESULTS AND DISCUSSION

### 1. Conditions for the Oxidation of Chromium to the Hexavalent State

For the separation of chromium in the hexavalent state by the wet air oxidation of shavings, the addition of alkali was necessary to stabilize

the hexavalent chromium formed in the course of oxidation. The wet air oxidation was therefore carried out with the addition of 0, 20, 40, 80 and 120% by weight of NaOH based on the dry weight of shavings, and then chromium dissolved in the oxidized liquor was determined. The results were shown in Table 1. In the absence of or in the presence of smaller amounts of NaOH, most of the chromium was found to be not oxidized and remained as precipitates of chromium oxide. When the amount of NaOH added attained to 80%, based on the dry weight of shavings, chromium was nearly completely oxidized to the hexavalent state and dissolved. The amount of organic matter remaining in the oxidized liquor was 25 g/l as COD or corresponded to about 10 times the weight of chromium. It was hence impossible to separate alkali salt of chromate by direct concentration of the oxidized liquor, but the recovery of a salt of hexavalent chromium would be possible after the separation of chromic ion through an ion exchange resin.

### 2. Conditions for the Removal of Chromium as Precipitates of Trivalent Chromium Compounds

For the separation of chromium in the shavings as precipitate, it was desirable to form that of low moisture and of readily separable one by filtration, and also it was desirable to form this precipitate as completely as possible to minimize the amount

TABLE 1. INFLUENCE OF ALKALI ADDITION UPON THE OXIDATION OF CHROME IN SHAVINGS

Amount of Sodium Hydroxide Added (%) <sup>*</sup>	Amount of Dissolved Chrome (Cr—mg./l.)			COD Remaining (g/l)	pH
	Total Chrome	Cr <sup>VI</sup>	Cr <sup>VI</sup> /Total (%)		
0	27.4	10.0	36.5	18	8.7
20	135	89	66.1	—	9.1
40	1689	1300	69.7	20	9.0
80	2738	2642	96.5	25	8.7
120	2281	2061	90.3	26	9.5

<sup>\*</sup>Based on the dry weight of shavings.

of dissolved chromium. In the case of higher acidity of the oxidized liquor, the precipitation of chromium oxide became insufficient, and contrary, in the case of alkalinity of the medium due to ammonia arisen from the decomposition of collagen might give rise to undesirable formation of hexavalent chromium. Hence, the wet air oxidation was carried out with the addition of 0, 5, 12.5 or 25% by weight of sulfuric acid based on the dry weight of the shavings. Table 2 showed the amount of chromium dissolved and the characteristics of precipitate. Upon addition of smaller amounts of sulfuric acid and consequently at a higher pH, chromium came out as green, strongly hydrated precipitate. As the amount of sulfuric acid added increased, brown, less hydrated sand-like precipitate was formed, and such precipitate was more readily separable by filtration or

centrifugation. Analyses of precipitates shown in Table 3 indicated that the oxidation carried out in an acidic medium leaved a large quantity of organic matters in the precipitates, and from this result, it was assumed that chromium was likely to be present not simply as chromium oxide but as complexes linked with organic matters.

The wet air oxidation by sulfuric acid was thus found to favour for the precipitation of chromium contained in shavings as less hydrated, sand-like precipitate which was readily filtrable. However, the filtrate still contained 100 ppm or more of dissolved chromium, then it was impossible to discharge as it was. Then the recycle utilization of the oxidized liquor was investigated.

As shown in Figure 2, the shavings initially charged were wet oxidized and the precipitates of chromium were separated, and the additional

TABLE 2. INFLUENCE OF SULFURIC ACID ADDED TO SHAVINGS IN THE WET AIR OXIDATION

Amount of Sulfuric Acid Added (%)*	Dissolved Chrome (Cr mg/1)	Property of Precipitated Chrome Compound	COD Remaining (g/1)	pH
0	27.4	brownish green, strongly hydrated	18	8.7
5	52.5		21	8.2
12.5	—		21	7.8
25	144	brown, less hydrated	14	4.6

\* Based on the dry weight of shavings.

TABLE 3. PROPERTY OF THE PRECIPITATE PRODUCED IN THE WET AIR OXIDATION OF SHAVINGS

Additive	Chrome Content (Cr <sub>2</sub> O <sub>3</sub> %)	Ash (%)	COD Content (%)	Ash + COD (%)
None	64.5	66.5	12.7	79.2
Sulfuric acid(25%)	47.4	50.3	32.4	82.7
Sodium hydroxide(20%)	71.0	74.4	5.9	80.3

## RECOVERY OF CHROMIUM FROM LEATHER SHAVINGS

charge of shavings was introduced so as to correspond to the decrease of COD caused by oxidation, and the wet air oxidation was once again performed. This procedure was repeated twice. In Process I, the oxidation was carried out without the further addition of sulfuric acid, while, in Process II, each 10% of sulfuric acid based on the dry weight of shavings were added to the reaction

mixture.

Table 4 showed the COD of the oxidized liquor and the amount of dissolved chromium after each oxidation step. In Process II, where the oxidized liquor was recycled with the addition of sulfuric acid, the rate of oxidation of the whole oxidized liquor was only about 70%, while the rate of oxidation for the recharged shavings reached

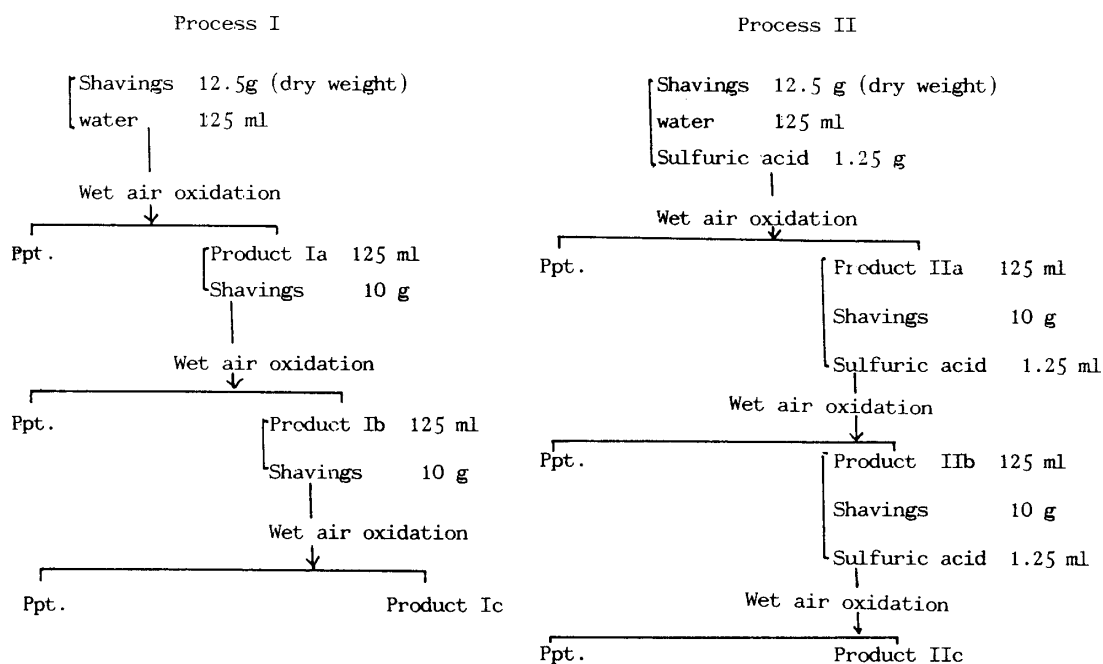

FIGURE 2. FLOW DIAGRAM OF THE WET AIR OXIDATION CYCLE OF SHAVINGS

TABLE 4. OXIDATION RATE OF SHAVINGS IN THE RECYCLED WET AIR OXIDATION

	Oxidation Product					
	Ia	Ib	Ic	IIa	IIb	IIc
Rate of oxidation(%)	75.3	70.4	66.4	73.0	69.1	69.6
Rate of oxidation for the recharged shavings(%)	—	85.9	80.5	—	83.3	88.0
Dissolved chrome (Cr—mg/l)	48.4	31.1	32.4	649.4	24.1	23.8
pH	8.7	8.8	9.0	7.8	8.3	8.3

a : First oxidation, b: Second oxidation, c: Third oxidation.

I : Without addition of sulfuric acid, II: With addition of sulfuric acid.

80% or more and the residual COD in the oxidized liquor did not show a tendency to increase markedly on recycling. Hence, it was possible to use the oxidized liquor repeatedly without discharging the liquor. Dissolved chromium in the oxidized liquor amounted to 20 ppm or more, but, since this liquor was not discharged from the system, this system seemed to be desirable from the view point of the pollution.

#### REFERENCES

1. Shirai, K. and Okamura, H.: Hikaku-Kagaku **21**, 10 (1975)
  2. Okamura, H., Ota H. and Morohashi, Y.: Hikaku-Kagaku **15** 119 (1969)
  3. Okamura, H., Ota H. and Morohashi, Y.: Hikaku-Kagaku **15**, 126 (1969)
  4. Nippon Hikaku Kenkyusho "Reports on Studies Commissioned by the Ministry of International Trade and Industry for the Fiscal Year 1971" march 31, (1972).
  5. Kashihara, H., Kato, T., Arima, J. and Mori, N.: Hikaku Kagaku, **18**, 198 (1972)
1. Shirai, K. and Okamura, H.: Hikaku-Kagaku

### シエービング屑の湿式酸化によるクロムの回収

岡村 浩

革・革製品および副産物の処理経路全体を考えると、最終的に廃棄される段階で、クロムの処理が問題となり、何らかの方法でクロム塩を回収し、再利用せねばならない。無公害的にクロム革屑、使用済み革製品等を燃焼灰化させ回収する方法については既報(学苑 NO.620, 54~64, 1991)に明らかにした。

本報では、シエービング屑より湿式酸化によりクロムを回収する方法について基礎的な検討を行った結果をとりまとめた。

シエービング屑を湿式酸化する場合、硫酸を添加し酸化するとクロムの大部分は汙過しやすい沈澱状態となり、沈澱率を高めるためには反応温度230℃以上が必要であった。また、湿式酸化処理液を再利用する循環方式が好ましいことが明らかとなった。